

# CCD COLOR BOARD CAMERA

**Specification:**

CCD COLOR CAMERA		
Item NO.	MS-C337GA	MS-C337PA
CCD Image Sensor	1/3 Interline CCD	
Number of Effective Pixels	510x492(NTSC)	
	500X582(PAL)	
Scanning System	2:1 INTERLACE	
Synchronization	INTERNAL	
Resolution (TV Lines)	380 TV LINE	
S/N Ratio	more than 48dB	
Minimum Illumination	0.2Lux at F 1.4	
Electronic Shutter	1/50 - 1/100000 sec.	
Horizontal Sync Frequency	NTSC-15.734kHz / PAL-15.625kHz	
Vertical Sync Frequency	NTSC-60Hz / PAL-50Hz	
Gamma Consumption	0.45	
Video Output	1Vp-p , 75ohms Composite	
Audio Output	Frequency 20-16000Hz,S/N ratio more than 58dB	
Built-In Lens	3.6mm/F2.0(G-type)/3.7mm/F2.0(P-type)	
Lens Angle	3.6mm/70 Degree	
Storage Temperature	-30 to 60 Degree C	
Working Temperature	-10 to 45 Degree C	
Power Source	DC 12V(standard)	
Power Current	150mA(max)	
Dimensions	35(W)X35(L)mm (by model for different)	

**Dimensions**

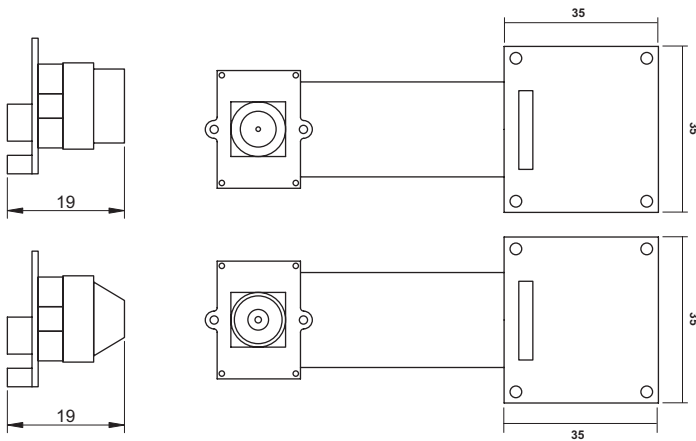

Unit:mm(Approx.)

Lens unit diameter and height differ for other lenses. Please inquire for details.

**CCD Board Camera:**



**MS-C337GA MICRO LENS**

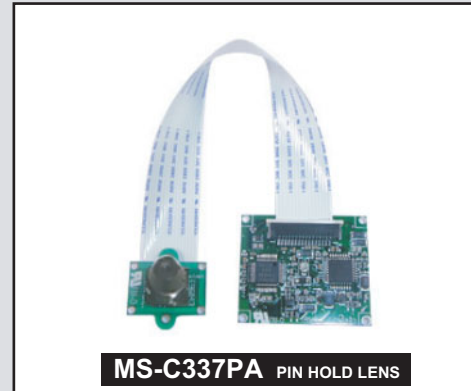

**MS-C337PA PIN HOLD LENS**

**Feature:**

- HIGH Quality Picture.**
- Compact size.**
- Mirror function:ordering in advance.**
- Backlight compensation.**
- Auto white balance.**
- Equipping Electronics-Auto-Iris.**
- Exchange for any kind of lens.**
- High Speed White Balance Mode(1Fild)**
- HIGH PERFORMANCE!**
- OUTSTANDING QUALITY!**
- COMPETITIVE PRICE!**